

TG100H Inductor Board

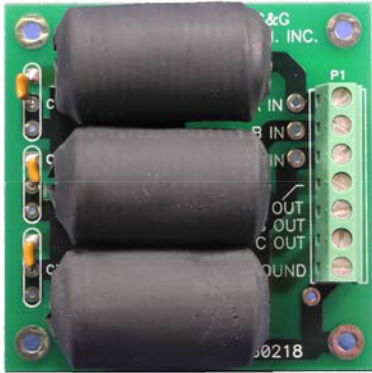

- Three phase for use with ThinGap® brushless motors
- Connects between amplifier and motor
- Easy terminal strip connection
- High-efficiency 100 μ H load matching
- Rated at 48 Vdc, 12 Amps continuous
- Meets typical 200 μ H in-line amplifier loading requirement
- Versions available for ThinGap brush motors
- Weight: 7.4 oz (211 g)
- Resistance per leg 15mOhms

THE THINGAP MOTOR

The ThinGap motor is a low-inductance, low-loss design, allowing nearly instantaneous response to pulse-width modulated (PWM) voltage waveforms from the amplifier. The low inductance may cause excessive current ripple and extra motor heating unless an inductor is connected in series between the motor and amplifier. This effect increases at lower PWM frequencies where the current may momentarily reverse during each PWM pulse impacting motor operation.

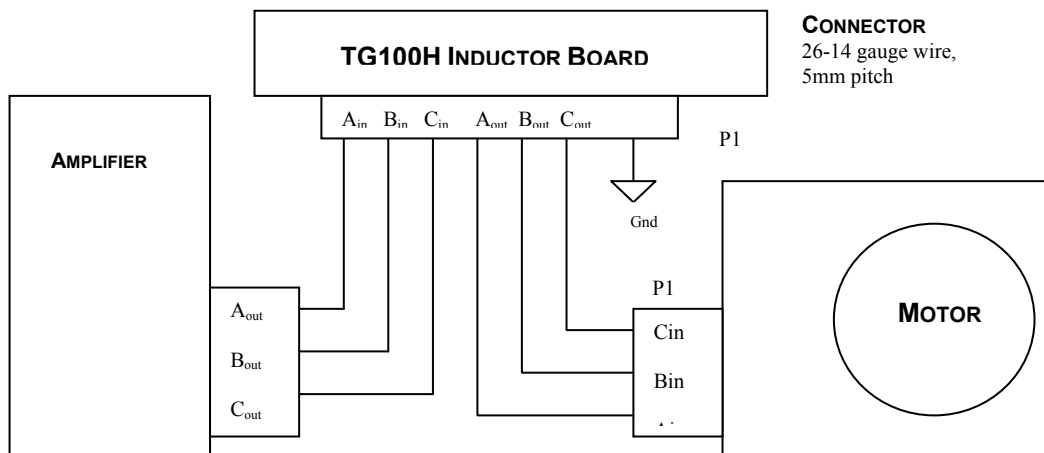
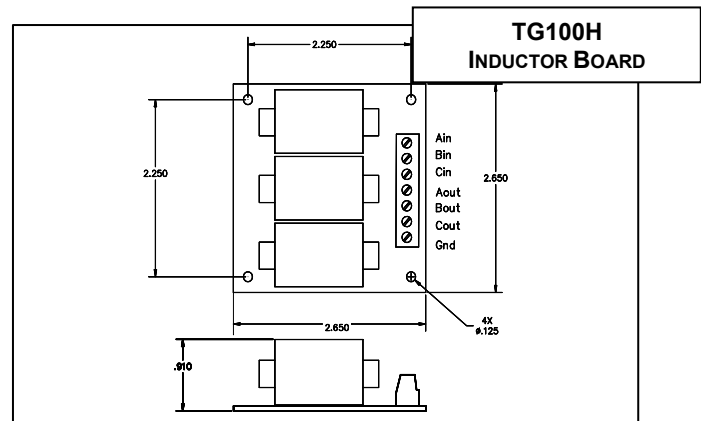

THINGAP CORPORATION
(805) 477-9741
(805) 477-7535 Fax