

- High power density
- 450 oz-in. peak torque
- 70 amps peak current
- Smooth, controllable power
- No cogging or hysteresis torque
- Other mounting and performance configurations available
- 8 Pole, Y Coil

TG2310 BRUSHLESS MOTOR					
	UNITS	IMPERIAL		SI	
Peak torque ¹	Tpk	450	oz-in.	3.18	Nm
Peak current	Ipk	60	amps		
Maximum Continuous rating:					
Torque -	Tc	92	oz-in.	0.65	Nm
Speed -	Wc	6645	rpm		
Current -	Ic	11.2	amps		
Voltage -	Vc	48	VDC		
Shaft Power	Pc	452	watts		
Maximum Locked Rotor Torque ²	Tlr	75	ozin	0.53	Nm
Maximum Locked Rotor Current	Ilr	9.3	Amps		
No load speed	Wnl	4,020	Rpm		
No load voltage	Vnl	24	Volts		
No load current	Inl	0.5			
Motor constant	Km	14.7	oz-in./sqrt (W)	0.104	Nm/sqrt(W)
Torque constant -trap drive	Kt	8.2	oz-in./amp	0.058	Nm/amp
Back EMF constant	Kv	0.058	v/rad./s		
Back EMF constant	Ke	165	rpm/volt		
Terminal resistance	Rt	0.31	ohms		
Cogging and hysteresis torque	Tc, Th	0	oz-in.		
Viscous drag torque	Tac	0.7	oz-in./krpm	4.94	mNm/krpm
Friction torque	Tfr	0.1	oz-in.	0.7	mNm
Stator inductance	L	20	micro H		
Mechanical time constant	Tm	18	mS		
Electrical time constant	Te	0.065	mS		
Maximum system Efficiency	Efficiency	84	%		
Motor weight, total	Wt. Total	21.0	oz	595	grams
Rotor inertia	J	2.80E-02	oz-in.-sec2	1.98E-04	Kg-m ²
Max rotor temperature ³	Temp rot	70	°C		
Max stator winding temperature ³	Temp wdg	110	°C		
NOTES:					
1-Torque vs current is linear and limited to short Duration					
2-Tested with the motor on a 3"x.375"x8" bracket using a 20amp, 48volt amplifier with 50uH inductors added per phase.					
3-Limited by magnet temperature stability at a fixed torque load.					

MOUNT IS -M1 VERSION

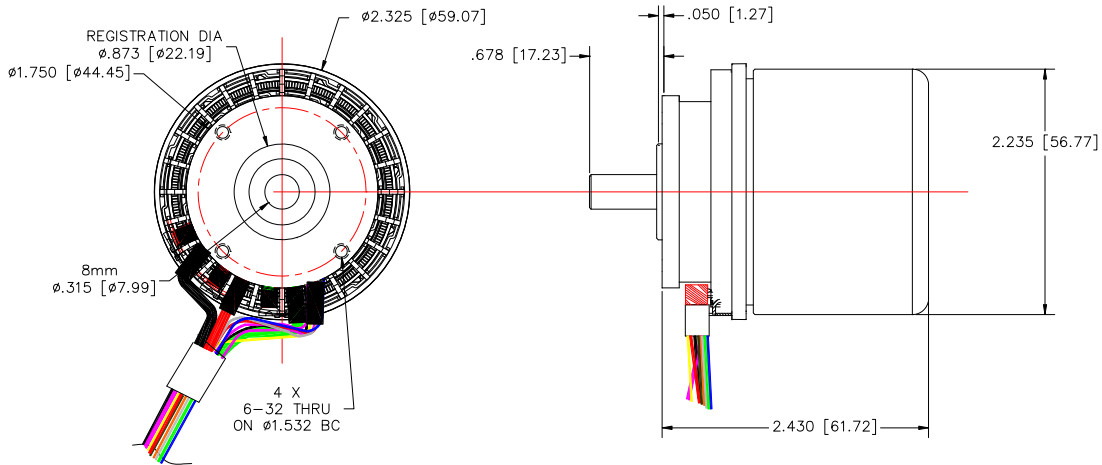

MOTOR PHASE	EXCITATION STEP					
	1	2	3	4	5	6
A	+	-	-	+	+	+
B	+	+	-	-	-	-
C	-	-	+	+	+	-
SENSOR OUTPUT						
H1	1	1	0	0	0	1
H2	0	1	1	0	0	0
H3	0	0	0	1	1	0

PHASE	WIRE COLOR
A	GRN
B	BLK
C	RED

PHASE	WIRE COLOR
+V	YELLOW
(-)	GREY
H1	BROWN
H2	ORANGE
H3	BLUE
O	VIOLET
I	VIOLET

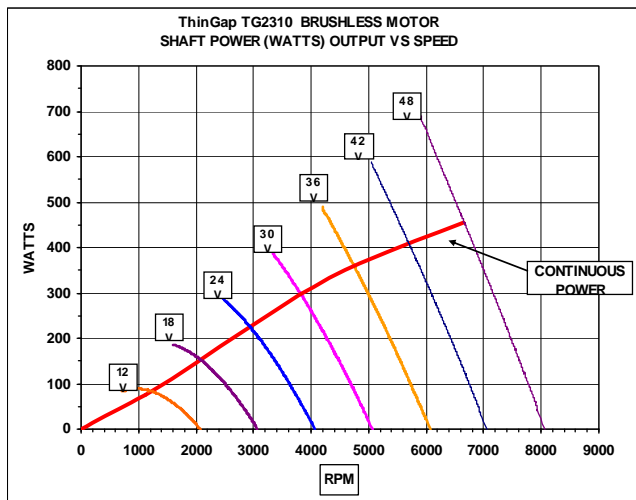
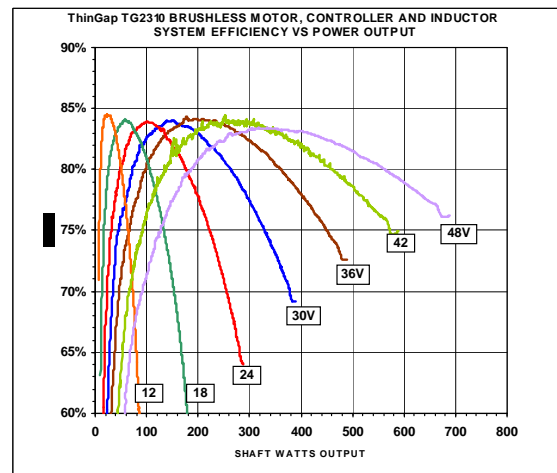
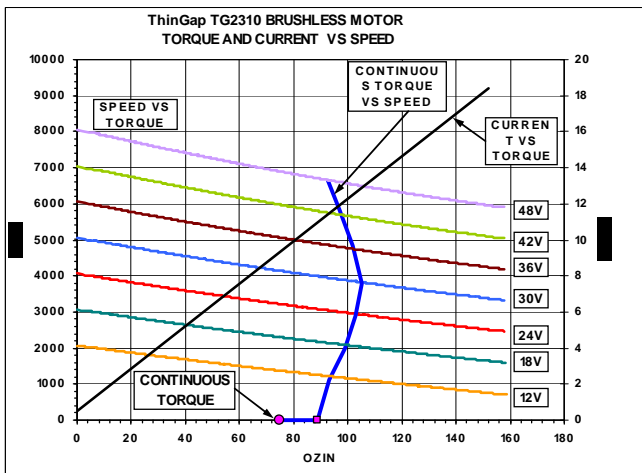

THINGAP CORPORATION
 (805) 477-9741
 (805) 477-7535 Fax