

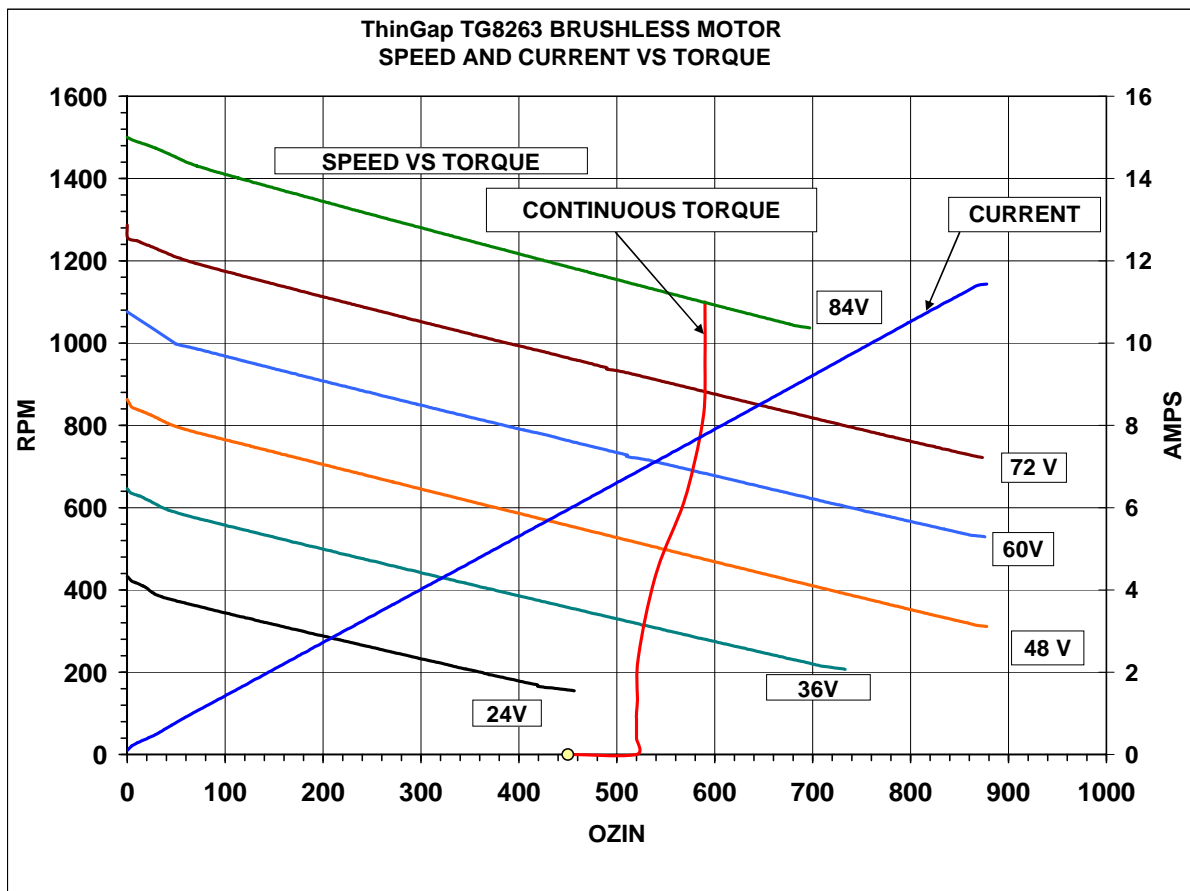

- 2075 oz-in. Peak Torque
- 1534 Watts Continuous Power
- Weight 45 oz
- 80% Peak System Efficiency
- Smooth, Controllable Power
- No Cogging or Hysteresis Torque

TG8260 SERIES BRUSHLESS MOTORS					
Peak torque ¹	T _{pk}		2075		oz-in.
Maximum Continuous Stall Torque	T _{lr}		415		ozin
Motor constant	K _m		49.7		oz-in./sqrt (W)
Cogging and hysteresis torque	T _c , T _h		0		oz-in.
Electrical time constant	T _e		0.038		mS
Mechanical time constant	T _m		109		mS
Stall Thermal Resistance	TPR ₁		0.81		deg C/WATT
Viscous drag torque	T _{ac}		7.23		oz-in./krpm
Windage friction	T _{w1}		0.249		oz-in./(krpm) ²
$T_w = T_{w1} * (KRPM)^2 + T_{w2} * KRPM$	T _{w2}		0.488		oz-in./krpm
Maximum System Efficiency	Eff system		80.0%		%
Maximum Motor Efficiency	Eff. Motor		88.0%		%
MAXIMUM VOLTAGE	V _{max}		84		Volts
Friction torque	T _{fr}		0.1		oz-in.
Motor weight, total	Wt. Total		45		oz
Rotor inertia	J		1.90		oz-in.-sec ²
Max rotor temperature ³	Temp rot		70		°C
Max stator winding temperature ³	Temp wdg		110		°C
MODEL NUMBER		TG8261	TG8262	TG8263	
Maximum Continuous rating ⁴ :					
Torque -	T _c	540	570	590	Oz-in
Speed -	W _c	3840	1920	960	Rpm
Current -	I _c	25.8	12.1	7.8	Amps
Voltage -	V _c	72	72	72	VDC
Shaft Power	P _c	1534	809	419	Watts
Current at Peak Torque	I _{pk}	104	53	27	Amps
Voltage at Peak Torque, locked rotor	V _{pk}	15	27	52	Volts
Maximum Continuous Stall Current	I _{lr}	22.3	11.2	5.6	Amps
No load speed	W _{nl}	4868	2497	1248	Rpm
No load voltage	V _{nl}	72	72	72	Volts
No load current	I _{nl}	0.9	0.4	0.2	Amps
Torque constant -trap drive	K _t	20	39	78	oz-in./amp
Back EMF constant	K _v	0.149	0.290	0.580	v/rad./s
Back EMF constant	K _e	64.2	32.9	16.5	rpm/volt
Terminal resistance	R _t	0.140	0.500	1.940	ohms
Stator inductance	L	10.0	40.0	160.0	micro H
NOTES:					
1-Caution, high torque. Torque increases linearly with current, without saturation.					
2-Maximum Temperature is Limited by magnet stability when testing at constant torque.					
All data are provided for a 25C ambient with motor mounted to a 8"x.375"x8" aluminum bracket					
3. Data includes the effect of inductors connected in series with each motor phase.					

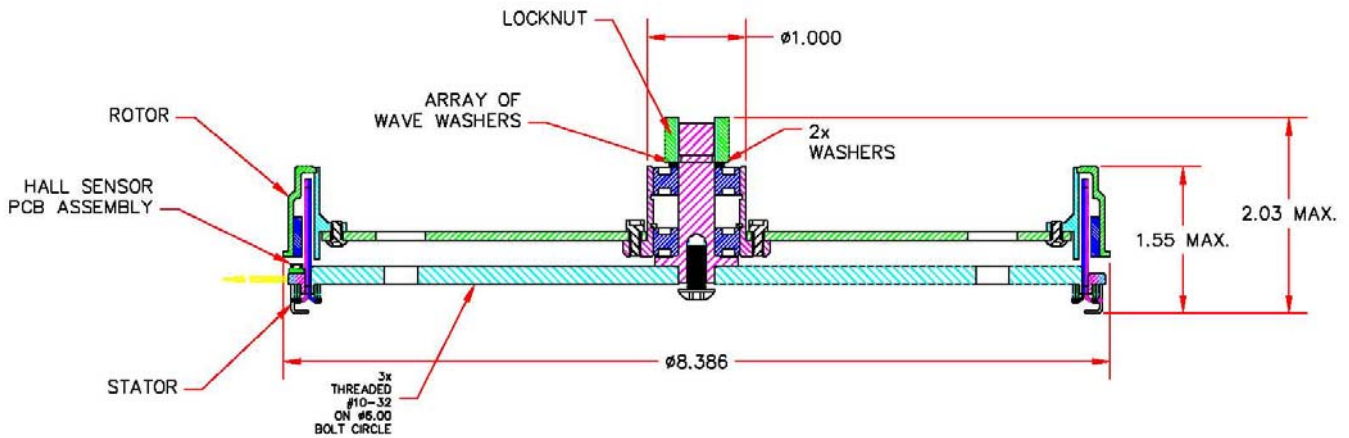

THINGAP LLC
 (805) 477-9741
 (805) 477-7535 Fax
info@thingap.com
www.ThinGap.com