



LS SERIES FRAMELESS MOTOR KIT

**HIGH TORQUE-TO-WEIGHT RATIO | LIGHT-WEIGHT AND LOW-INERTIA | HIGHLY EFFICIENT
RING ARCHITECTURE | ZERO COGGING FOR PRECISION MOVEMENT | SCALABLE IN SIZE AND POWER**

Data Sheet Model Number: LSI 130-23

ThinGap's LS Line includes numerous high performance brushless permanent magnet motors. The LS line targets lower speed, high precision applications such as gimbals, optics, and precision robotics. The highest torque density with high power capability and low thermal resistance.

Motor Parameter Table

Continuous Parameters	Units	Value
Continuous Torque @ Max Speed	N-m	2.25
Max Continuous Speed	RPM	1530
Max Continuous Power	W	361.0
Required Motor Voltage @ Max Speed	V_{pk-l}	81
Max Continuous Phase Current @ Max Speed	A_{RMS}	4.39
Peak Parameters@Max Speed	Units	Value
Peak Torque (1 sec)*	N-m	12.10
Peak Phase Current (1 sec)	A_{RMS}	22
Peak Power (1 sec)*	W	1939
Motor Constants	Units	Value
Voltage Constant (I-I)	$V_{pk-l}/rad/s$	0.460
Voltage Constant (I-I)	$V_{pk-l}/kRPM$	48.166
Torque Constant	N-m/ A_{RMS}	0.563
Motor Constant	N-m/ \sqrt{W}	0.396
Electrical Parameters	Units	Value
Terminal Resistance @ 20°C	Ω	1.431
Terminal Resistance @ Max Temperature	Ω	1.888
Terminal Inductance	μH	84.78 \pm 20%
Number of Magnetic Poles	ea	26
Electrical Frequency @ Max Speed	Hz	332
Mechanical Parameters	Units	Value
Rotor Inertia	$kg\cdot m^2$	1.520E-03
Outer Diameter	mm	130
Through Hole Diameter	mm	95.3
Axial Height	mm	22.9
Rotor Mass	kg	0.528
Stator Mass	kg	0.309
Part Set Mass	kg	0.837
Temperature Parameters	Units	Value
Max Stator Temperature	°C	130
Max Rotor Temperature	°C	85
Thermal Resistance	°C/W	2.01

All motor parameters calculated assuming 20° C ambient temperature and the motor kit not being installed into a housing. Thermal resistance can drop by 30% when mounted.

*Includes temperature effects and losses from speed



ThinGap's LS Line of Brushless Motors
For low speed, high precision applications such as gimbals, optics, and precision robotics. Highest torque density with high power capability. Available in sizes 25mm to 267mm.

Torque and Mechanical Speed:

Continuous rated torque of up to 2.25 N-m and rated speed of up to 1530 RPM.

Motor Controller Recommendation:

Standard 3-Phase Controller
High frequency PWM recommended

Custom Variants Available Upon Request:

Alternative winding design options
Higher speed options
High temperature option
Two Phase Winding





Motor Data Sheet Model Number: LSI 130-23

ThinGap technology incorporates the latest electro-magnetic components where torque limits, both continuous and peak, are determined by available cooling. The charts presented develop these limits based on natural convection from the lamination stack surface with forced convection on the coil surface due to rotation of the rotor. Mounting of the laminations stack to a heat sink will further improve maximum continuous torque capacity. Contact ThinGap for application-specific requirements.

ThinGap's frameless motor part set allows it to be completely integrated resulting in the highest ratio of torque-to-volume. In this configuration, the motor's rotor and stator can be housed within the customer's assembly utilizing a common shaft and bearing system, resulting in increased coupling efficiencies, smaller system size and lower weight. **Note:** stator and rotor assembly requires tooling due the high magnetic strength of ThinGap's rotor designs.

Similar Frame Sizes Available:

Motor Model (mm)	Continuous Torque (N-m)
LSI 75-12	0.29
LSI 75-20	0.66
LSI 75-30	1.04
LSI 105-33	1.9
LSI 130-40	4.24
LSI 152-29	3.58
LSI 152-55	8.36
LSI 267-32	11.54
LSI 267-58	24.4

(Custom sizes also available.)

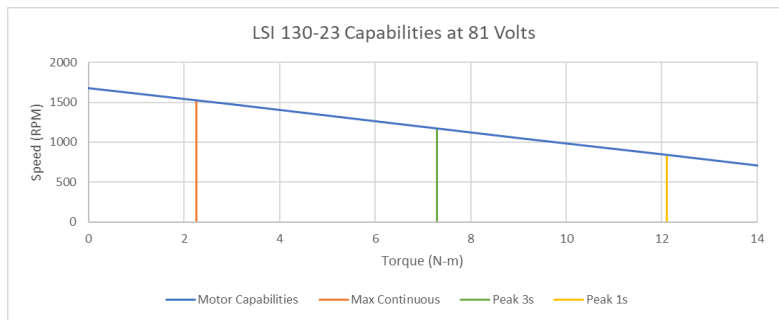

Example of Typical Use Speed-Torque Curve
Higher speeds possible and is dependent on the applied voltage. Top speed may be limited mechanically. Please consult factory if higher speeds are required.

LSI 130-23 Mechanical Information

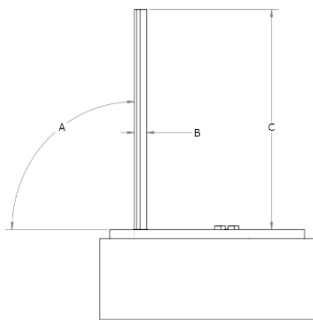

Lead Wire Configuration Table			
Configuration	Wire Exit Angle "A"	Wire Exit Clearance "B"	Wire Length "C"
Solder Pads	No Wires	No Wires	No Wires
Axial	90°	0.30" x 0.10"	18"
Radial Out	0°	0.30" x 0.10"	18"
Radial In	180°	0.30" x 0.10"	18"

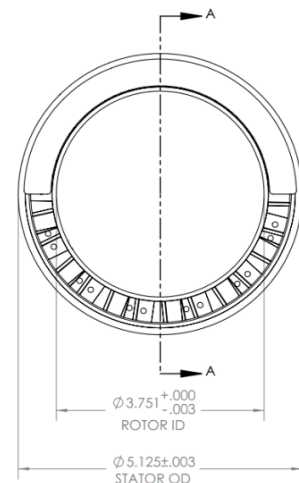
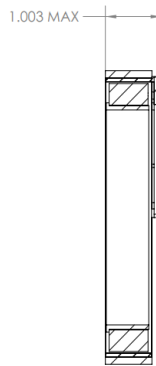

General Mechanical Specifications
All values should be considered nominal. Please consult factory for up-to-date mechanical drawing and ICD.

ThinGap is a leading designer and producer of US-made standard and custom motors and generators. In addition to the LS Line (presented above) for lower speed, high precision applications, the TG Line offers the highest power density motor design with high torque and inherent high-speed capability in sizes 25mm to 1 meter, and powers from mW to MW. ThinGap also develops custom and application-specific motors, such as carbon fiber-based designs and large clean output starter generators. ThinGap's high performance, zero cogging motors and generators are widely used in aerospace propulsion, hybrid power, space, medical and high-end industrial applications.

