



thin gap | TG SERIES MOTOR KIT

ZERO COGGING | OPTIMIZED FOR POWER DENSITY | LIGHT-WEIGHT AND LARGE APERTURE
HIGHLY EFFICIENT ARCHITECTURE | IRONLESS COMPOSITE STATOR | SCALABLE SIZE AND POWER

Data Sheet Model Number: **TG 234X-XX**

ThinGap's TG Series includes numerous high performance brushless permanent magnet motors. The TG Series targets higher speed, high-precision applications such as where a smooth motion and weight optimized solution is desired.



ThinGap's TG Line of Brushless motors designed for high speed, high power power applications such as propulsion, reaction wheels, and precisions industrial. These motor kits are available in sizes ranging from 57mm to 190 mm

Model Number Nomenclature	TG 23 4 X -XX
Motor Series	TG 23
Rotor Configuration	4
Winding Configuration (0-WYE, 1-Delta)	X
Mounting Option (M1/M2-Framed, P1- Frameless Part Set)	-XX
Example	TG 2341-M1

Winding Independent Parameter Table

TG 234X

Performance Parameters	Units	Value
Continuous Torque @ Max Speed	N-m	1.02
Max Continuous Speed	RPM	6500
Max Continuous Power	W	680
Peak Parameters @ Max Speed	Units	Value
Peak Torque (1 sec)	N-m	3.69
Peak Torque (3 sec)	N-m	2.2
Mechanical Parameters	Units	Value
Rotor Inertia	kg-m ²	4.17E-04
Number of Magnetic Poles	ea	8
Outer Diameter	mm	67
Through Hole Diameter	mm	33
Axial Height	mm	62
Part Set Mass (Rotor and Stator)	kg	0.674
Total Motor Mass M1	kg	0.836
Total Motor Mass M2	kg	0.856
Temperature Parameters	Units	Value
Max Stator Temperature	°C	100

Torque and Mechanical Speed

Continuous rated torque of up to 1.02 N-m and a rated speed of up to 6500 RPM.

Motor Controller Recommendation

Standard 3-Phase Controller
High Frequency PWM power input

Resources for Integration

CAD files at: www.thingap.com

Complete Mechanical drawings available upon request

Winding dependent Parameter Table

TG 2340

TG 2341

Electrical Parameters	Units	Value	Value
Winding Configuration		WYE	DELTA
Required Motor Voltage @ Max Speed	V _{pk-l}	51.4	29.1
Max Continuous Phase Current @ Max Speed *	A _{RMS}	12.0	18.0
Voltage Constant (l-l)	V _{pk-l} /rad/s	0.07	0.04
Voltage Constant (l-l)	V _{pk-l} /kRPM	7.3	4.2
Torque Constant	N-m/A _{RMS}	0.085	0.057
Motor Constant	N-m/vW	0.125	0.125
Terminal Resistance	Ω	0.31	0.103
Terminal Inductance	μH	20.6	6.9

* Current value takes into account temperature losses during operation.



TG SERIES
MOTOR KIT

TG 234X-XX

TG 234X-XX Mechanical Information

TG 234X-P1

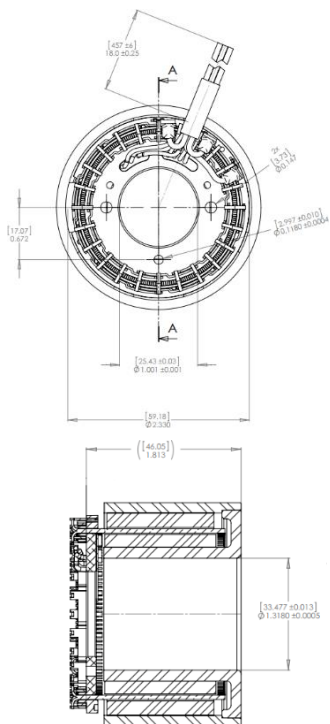

TG 234X-M1

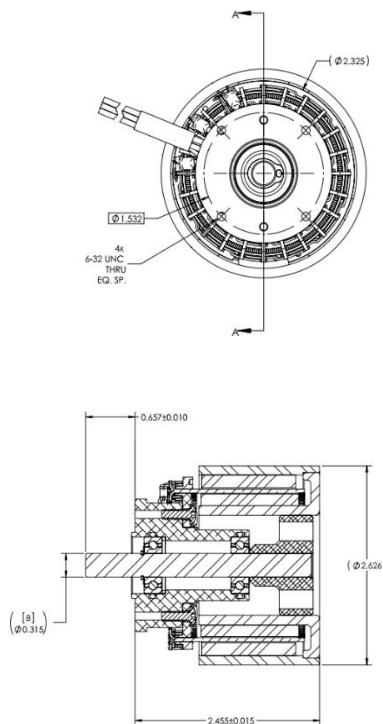

TG 234X-M2

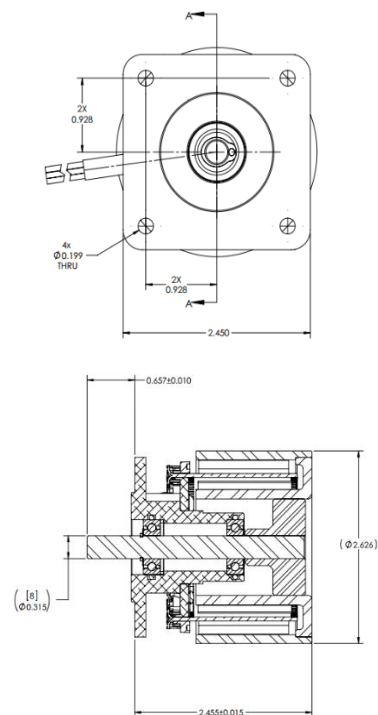

General Mechanical Specifications

All values should be considered nominal. Please consult factory for up-to date mechanical drawing and ICD.

TG Series Options and Motor Capabilities

Basic Kit Sizes Available:				
TG Sub-Series	Motor Model	OD (inch/mm)	Con.Torque (N-m)	Max Speed (RPM)
2 Series (2" OD)	TGI 231X	2.2 / 57	0.74	6,500
	TGO 232X	2.2 / 57	0.35	16,000
	TGO 233X	2.2 / 57	0.69	16,000
	TGD 234X	2.2 / 57	1.02	6,500
3 Series (3" OD)	TGI 046	1.8 / 46	0.71	3,300
	TG 303X	2.8 / 71	0.14	30,600
4 Series (4" OD)	TG 304X	2.9 / 75	0.19	28,400
	TG 305X	3.0 / 76	0.21	17,900
5 Series (5" OD)	TG 513X	5.2 / 131	1.68	18,400
	TG 514X	5.4 / 136	2.65	13,900
	TG 515X	5.5 / 138	3.57	10,300
7 Series (7" OD)	TG 713X	7.0 / 178	2.98	13,700
	TG 714X	7.2 / 182	4.26	10,800
	TG 715X	7.5 / 190	4.83	10,300
	TGO 190	7.5 / 190	9.46	6000

