



# thin gap | TG SERIES MOTOR KIT

**ZERO COGGING | OPTIMIZED FOR POWER DENSITY | LIGHT-WEIGHT AND LARGE APERTURE  
HIGHLY EFFICIENT ARCHITECTURE | IRONLESS COMPOSITE STATOR | SCALABLE SIZE AND POWER**

## Data Sheet Model Number: **TG 715X-XXXX**

ThinGap's TG Series includes numerous high performance brushless permanent magnet motors. The TG Series targets higher speed, high-precision applications such as where a smooth motion and weight optimized solution is desired.



ThinGap's TG Line of Brushless motors designed for high speed, high power applications such as propulsion, reaction wheels, and precisions industrial. These motor kits are available in sizes ranging from 57mm to 190 mm

Model Number Nomenclature	TG 71 5 X -XXXX
Motor Series	TG 71
Rotor Configuration	5
Winding Configuration (0-WYE SERIES, 2-WYE PARALLEL, 3-DELTA PARALLEL)	X
Mounting (P010-Frameless, M010-Framed)	-XXXX
Example	TG 7150-M010

### Winding Independent Parameter Table **TG 715X**

Performance Parameters	Units	Value
Continuous Torque @ Max Speed	N-m	4.83
Max Continuous Speed	RPM	10300
Max Continuous Power	kW	4.04
Peak Parameters @ Max Speed	Units	Value
Peak Torque (1 sec)	N-m	23.25
Peak Torque (3 sec)	N-m	13.55
Mechanical Parameters	Units	Value
Rotor Inertia	kg-m <sup>2</sup>	6.84E-03
Number of Magnetic Poles	ea	32
Outer Diameter	mm	190
Through Hole Diameter	mm	161
Axial Height	mm	39
Part Set Mass (Rotor and Stator)	kg	1.079
Total Motor Mass M1	kg	1.588
Temperature Parameters	Units	Value
Max Stator Temperature	°C	100

### Torque and Mechanical Speed

Continuous rated torque of up to 4.83 N-m and a rated speed of up to 10300 RPM.

### Motor Controller Recommendation

Standard 3-Phase Controller  
High Frequency PWM power input

### Resources for Integration

CAD files at: [www.thingap.com](http://www.thingap.com)

Complete Mechanical drawings available upon request

### Winding dependent Parameter Table

Electrical Parameters	Units	TG 7150	TG 7152	TG 7153
		Value	Value	Value
Winding Configuration		WYE SERIES	WYE PARALLEL	DELTA PARALLEL
Required Motor Voltage @ Max Speed	$V_{pk-l}$	230.9	115.5	66.9
Max Continuous Phase Current @ Max Speed *	$A_{RMS}$	20.4	40.8	61.1
Voltage Constant (I-I)	$V_{pk-l}/rad/s$	0.21	0.105	0.061
Voltage Constant (I-I)	$V_{pk-l}/kRPM$	22	11	6.4
Torque Constant	$N-m/A_{RMS}$	0.257	0.129	0.086
Motor Constant	$N-m/\sqrt{W}$	0.433	0.433	0.433
Terminal Resistance	$\Omega$	0.236	0.059	0.02
Terminal Inductance	$\mu H$	20.5	5.1	1.7

\* Current value takes into account temperature losses during operation.



# thin gap | TG SERIES MOTOR KIT

**TG 715X-XXXX**

**TG 715X-XXXX Mechanical Information**

**TG 715X-P010**

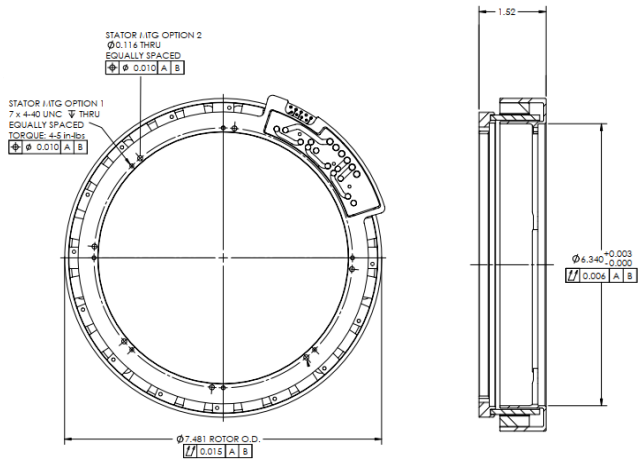

**TG 715X-M010**

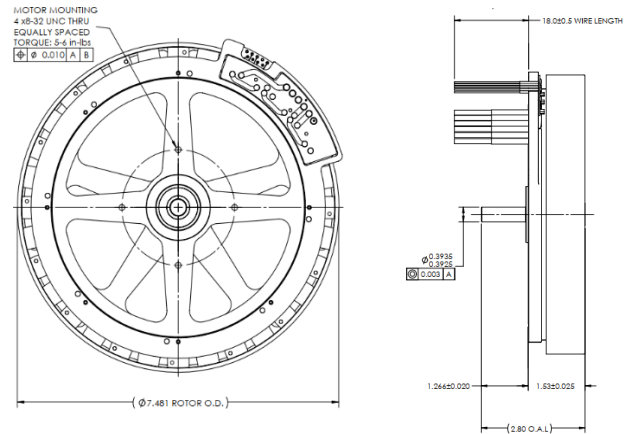

**General Mechanical Specifications**

All values are in inches and should be considered nominal. Please consult factory for up-to date mechanical drawing and ICD.

**TG Series Options and Motor Capabilities**

Basic Kit Sizes Available:				
TG Sub-Series	Motor Model	OD (inch/mm)	Con.Torque (N-m)	Max Speed (RPM)
2 Series (2" OD)	TGI 231X	2.2 / 57	0.74	6,500
	TGO 232X	2.2 / 57	0.35	16,000
	TGO 233X	2.2 / 57	0.69	16,000
	TGD 234X	2.2 / 57	1.02	6,500
	TGI 046	1.8 / 46	0.71	3,300
3 Series (3" OD)	TG 303X	2.8 / 71	0.14	30,600
	TG 304X	2.9 / 75	0.19	28,400
	TG 305X	3.0 / 76	0.21	17,900
4 Series (4" OD)	TGO 110	4.3 / 110	0.99	4,000
5 Series (5" OD)	TG 513X	5.2 / 131	1.68	18,400
	TG 514X	5.4 / 136	2.65	13,900
	TG 515X	5.5 / 138	3.57	10,300
7 Series (7" OD)	TG 713X	7.0 / 178	2.98	13,700
	TG 714X	7.2 / 182	4.26	10,800
	TG 715X	7.5 / 190	4.83	10,300
	TGO 190	7.5 / 190	9.46	6000

**REGION OF OPERATION**

