



TG3200 SERIES BRUSH MOTOR

- High power density
- High torque
- High efficiency
- No cogging or hysteresis
- No iron losses
- No lamination ringing
- Rapid acceleration
- Low-inductance armature
- Compact and lightweight
- Innovative, patented coil design



TG3200 Series Brush Motor	-35A	-42A
Peak torque (T_{peak})	115 oz-in.	115 oz-in.
Continuous shaft power (P_{cont})	300 W	260 W
Torque (T_{cont})	23 oz-in.	23 oz-in.
Current (I_{cont})	32.6 amps	26.5 amps
Max efficiency @ 25 °C	82%	88%
Max speed (ω_{max})	35,000 rpm	35,000 rpm
No load speed (ω)	22,000 rpm @ 12 V _{DC}	17,700 rpm @ 12 V _{DC}
Motor constant (K_m)	2.8 oz-in./sqrt (W)	2.7 oz-in./sqrt (W)
Torque constant (K_t)	0.72 oz-in./amp.	0.87 oz-in./amp.
Back EMF constant (K_e)	1875 rpm/v	1550 rpm/v
No load current (I_o)	2.7 amps	1.9 amps
Terminal resistance. (R_t)	0.054 Ω	0.094 Ω
Armature resistance (R_m)	0.048 Ω	0.088 Ω
Cogging and hysteresis torque (T_c)	0 oz-in.	0 oz-in.
Viscous drag torque (T_{ac})	0.74 oz-in./krpm	0.74 oz-in./krpm
Friction torque (T_{fr})	1.0 oz-in.	1.0 oz-in.
Ambient temperature range	-34 to 160 °C	-34 to 160 °C
*Max armature winding temperature	120 °C	120 °C
Thermal resistance (TPR)	1.76 °C/W	1.76 °C/W
Armature Inductance (L)	<10 μ H	<15 μ H
Starting current	0.5 amps @ 0.08 V _{DC}	0.5 amps @ 0.08 V _{DC}
Armature weight (W_a)	1.76 oz	1.76 oz
Motor weight (W_i)	10 oz	10 oz
Armature inertia (J)	9.96×10^{-4} oz-in.-s ²	9.96×10^{-4} oz-in.-s ²
Max continuous winding temperature is limited by maximum magnet temperature of 120 °C.		
Peak power is limited to the temperature rise of the armature. Integrated fan for forced air cooling.		
Magnet material: Neodymium. Bearing type: Ball. Brush: Silver graphite.		
Motor testing performed at 25 °C ambient with mounting heat sink of 3" x 3/8" x 8" aluminum.		



TG3200 SERIES BRUSH MOTOR

OUTLINE DRAWING

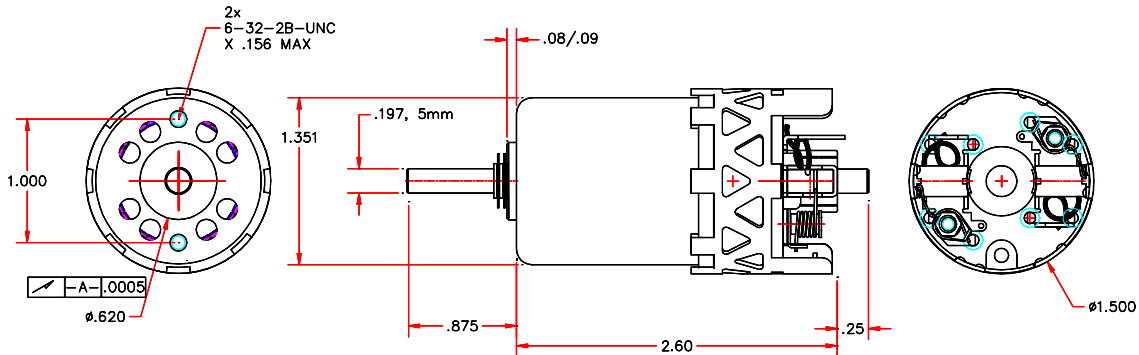

TG3200 SERIES

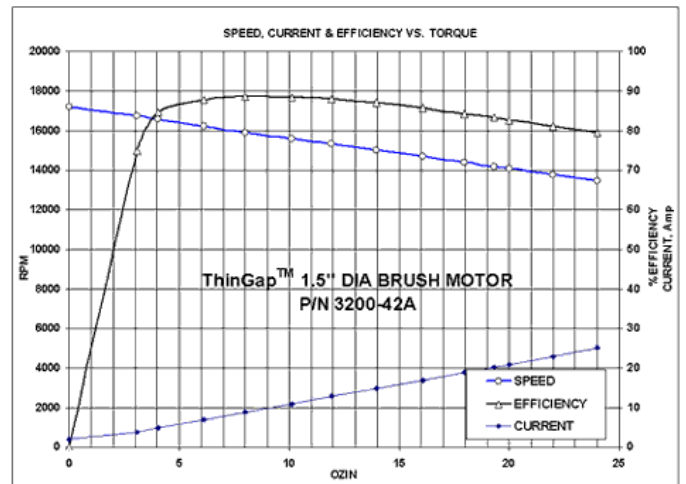
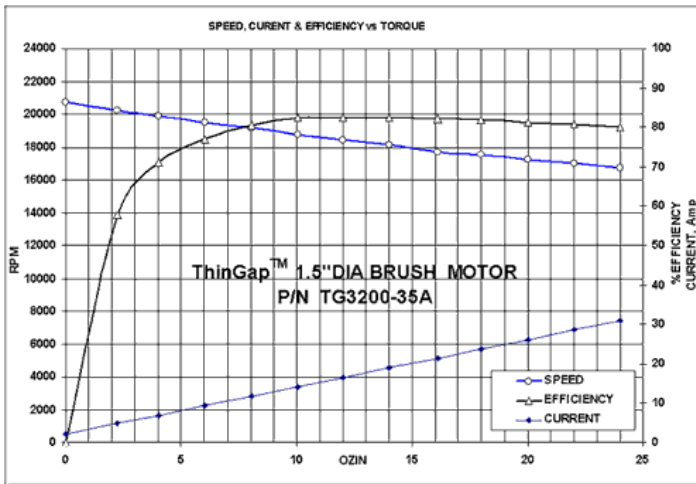

THINGAP MOTOR TECHNOLOGIES

(805) 477-9741
 (805) 477-7535 Fax
 info@thingap.com
 www.ThinGap.com